

**CUBE Series**

**D5532 .17**

Integral Socket with Switch 13A International Multi Socket Shuttered - 2 module Charcoal Black

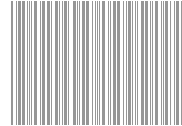

5267.51.8



Code:	D5532 .17
Series:	CUBE Series
Family:	Integral Sockets
Module Size:	Two Module
Colour:	Charcoal Black
Mark:	Norisys
Rated supply voltage:	240V
Maximum resistive load:	13A
Dimensions:	60.0mm x 52.2mm x 35.5mm
Weight:	89.10g

**Wiring Diagram:**

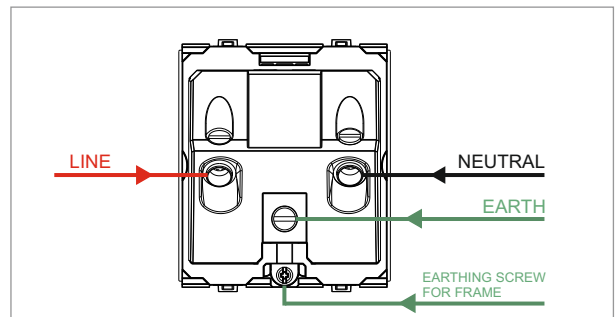

**Drawings:**

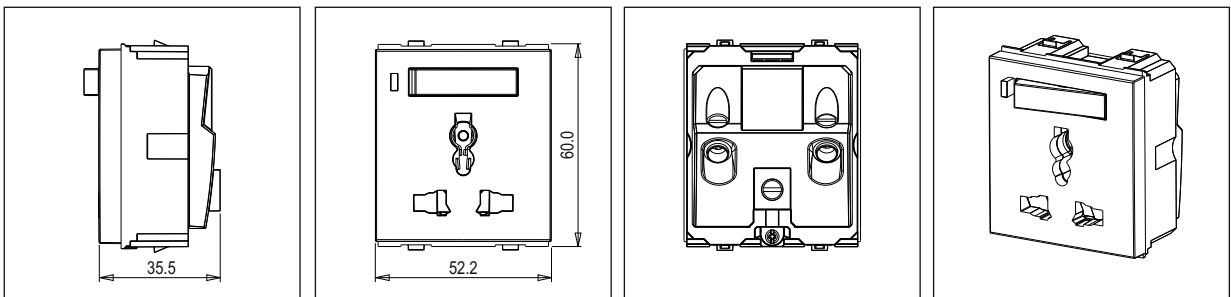

**Installation:**

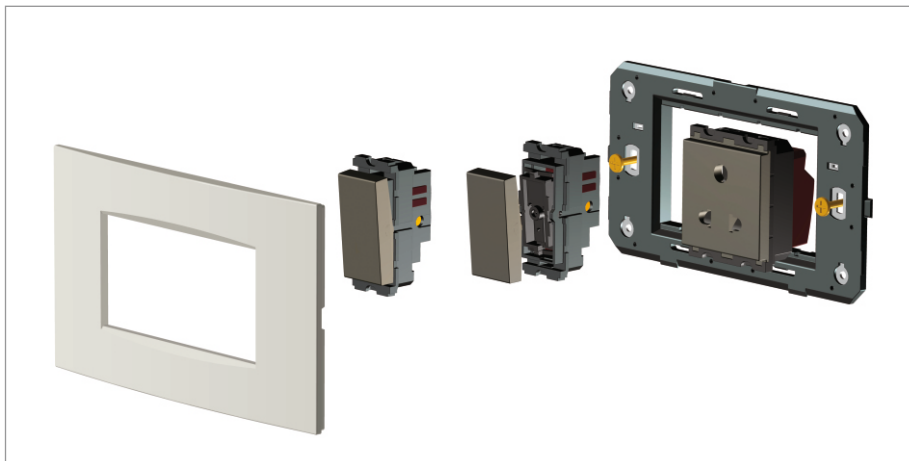

Installation of the product should be carried out in compliance with the current regulations regarding the installation of electrical systems in the country where the product is installed.

The product should be installed by a trained professional following all safety norms.

Keep away from water and wet surfaces. While mounting the product, hands should not be wet.