

CUBE Series

D5332 .17

Integral Socket with Switch 16A/6A 3-Pin Shuttered - 2 module Charcoal Black

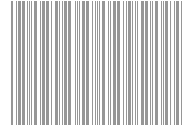

5267.51.8



Code:	D5332 .17
Series:	CUBE Series
Family:	Integral Sockets
Module Size:	Two Module
Colour:	Charcoal Black
Mark:	Norisys
Rated supply voltage:	240V
Maximum resistive load:	16/6A
Dimensions:	60.0mm x 52.2mm x 35.5mm
Weight:	89.10g

Wiring Diagram:

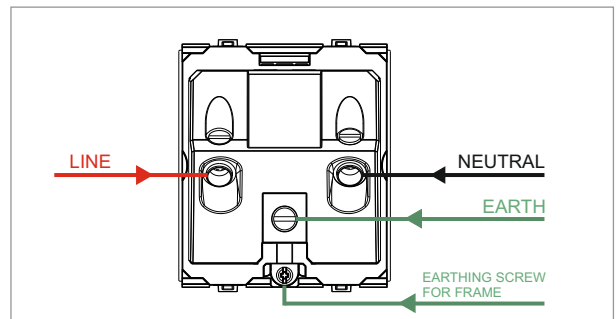

Drawings:

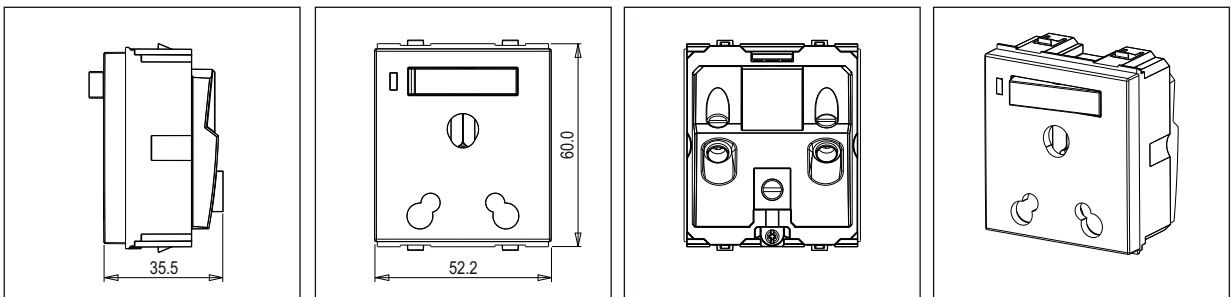

Installation:



Installation of the product should be carried out in compliance with the current regulations regarding the installation of electrical systems in the country where the product is installed.

The product should be installed by a trained professional following all safety norms.

Keep away from water and wet surfaces. While mounting the product, hands should not be wet.